

HOLINGER

MF-E9

MITSUBISHI EVO 4-9 SEQUENTIAL GEARBOX

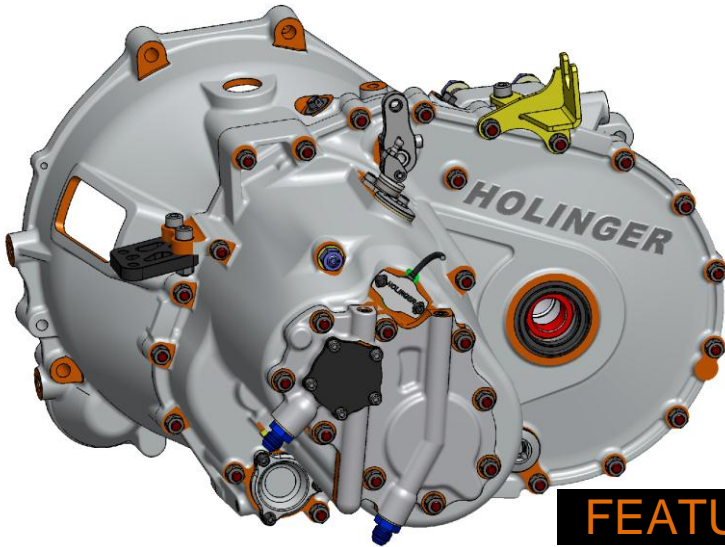

FEATURES:

- Sequential shift 6-speed transaxle designed for use in the Mitsubishi Lancer Evolution 4-9.
- The MF-E9 is a complete gearbox, replacing the original Mitsubishi unit between the engine and the transfer case.
- Torque rating for endurance events is 700Nm (520ft.lb).
- The gearbox is fitted with 6 forward gears, a reverse gear set and a ring & pinion. All gears are profile ground for increased efficiency and durability.
- All gears have an extensive range of ratios available, the 1st pinion gear is integral with the shaft. Forward gear ratios can range between 3.33-0.88:1. Output ratios can range between 4.85-3.05:1.
- The centre differential is included and compatible with all EVO 4-9 mechanical and active (ACD, AYC) systems / transfer cases.
- The internal lubrication system consists of a magnetic / paper element filter, an oil pump with provision for an external cooler, a spray bar to feed cooled oil directly onto the gears, through-shaft lubrication to all needle roller bearings and oil feed for the transfer case.
- The original speedometer system is compatible.
- Output is designed to work with the standard Mitsubishi tripods and drive-shafts. Holinger can supply optional stronger shafts if required
- The original clutch, slave-cylinder and fork are compatible.
- The original front and rear mounts can be used. A new top mount is supplied with the gearbox.
- A stand-alone gear-lever system with an integral shift-cut trigger is available. Holinger can supply a complete floor mounted system with cables to interface with the gearbox.
- A gear position sensor is supplied for interfacing with an electronic dash display. Alternatively a stand-alone gear indicator display is available for cars not fitted with an electronic dash.
- A temperature sensor can be installed on the gearbox (M12x1.5).
- Case hardened Nickel Chrome steel is used for all gears and shafts.
- The selector forks are manufactured from high tensile, nitrided steel.
- Casings are sandcast Aluminium alloy, heat treated to T6 specifications.
- O-ring seals are used on all joint faces.
- Gearbox weight is 50kg (110lbs).

Holinger Engineering Co. Pty Ltd.

12-14 Southfork Drive, Kilsyth, Vic, 3137, Australia.

Phone Number +61 3 9761 7964 Fax Number +61 3 7961 7965

Email info@holinger.com.au Website www.holinger.com.au



HOLINGER

MF-E9

**MITSUBISHI EVO 4-9
SEQUENTIAL GEARBOX**

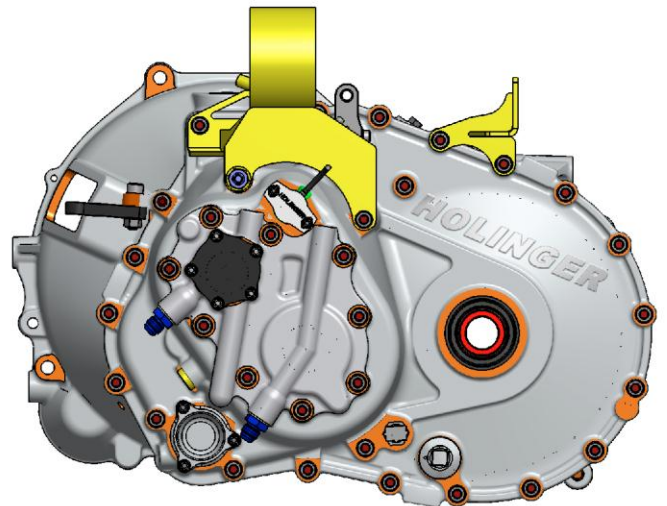
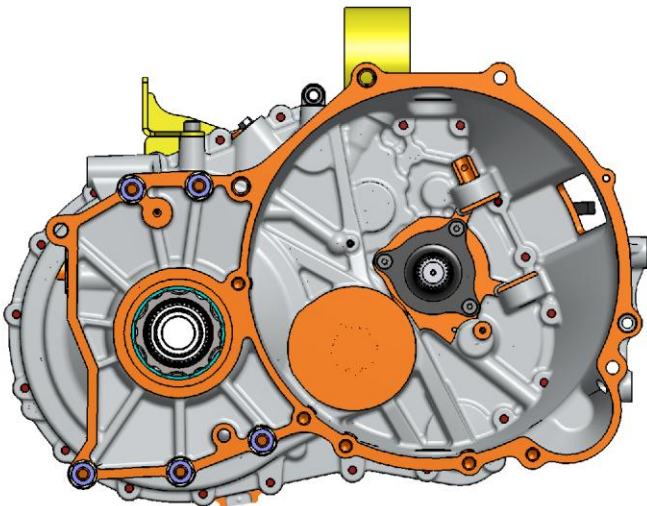
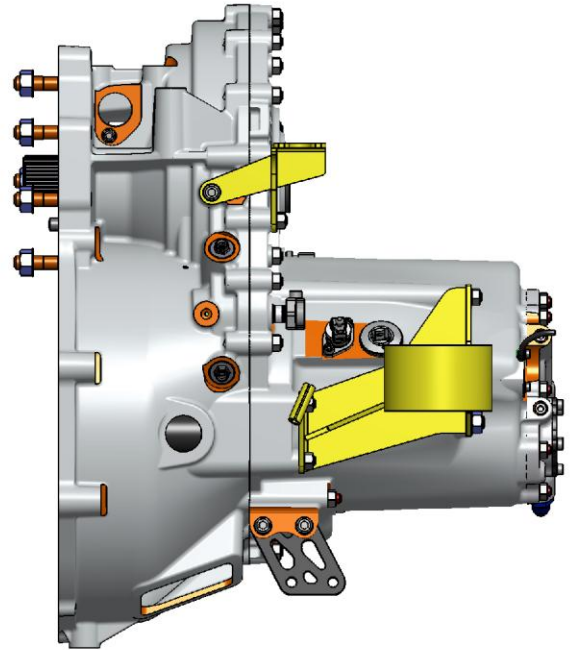
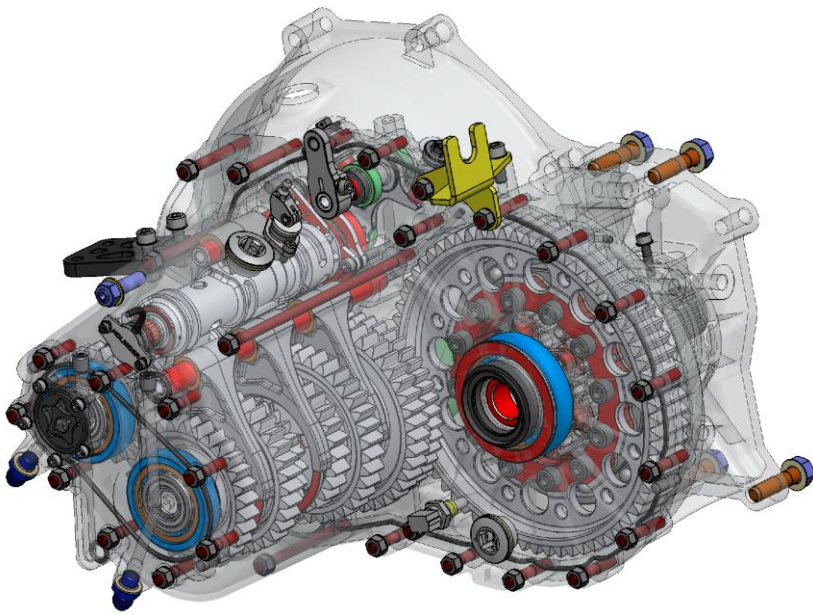

Holinger Engineering Co. Pty Ltd.

12-14 Southfork Drive, Kilsyth, Vic, 3137, Australia.

Phone Number +61 3 9761 7964 Fax Number +61 3 7961 7965

Email info@holinger.com.au Website www.holinger.com.au

